

Introduction

LT-15 is fitted to radiators and is used to control the temperature within the room. When used properly, they will significantly reduce the energy used by the heating system by limiting the temperatures within each room and prevent overheating.

Technical Specification

- Maximum working pressure 10 bar
- Maximum flow temperature 120°C
- Maximum differential pressure 0.8bar
- Nominal flow rate 173kgs/h
- Temperature range 7°C to 28°C with frost protection
- Reversible bi-directional body
- In-built sensor with liquid filled element
- Horizontally or vertically installation

Dimensions

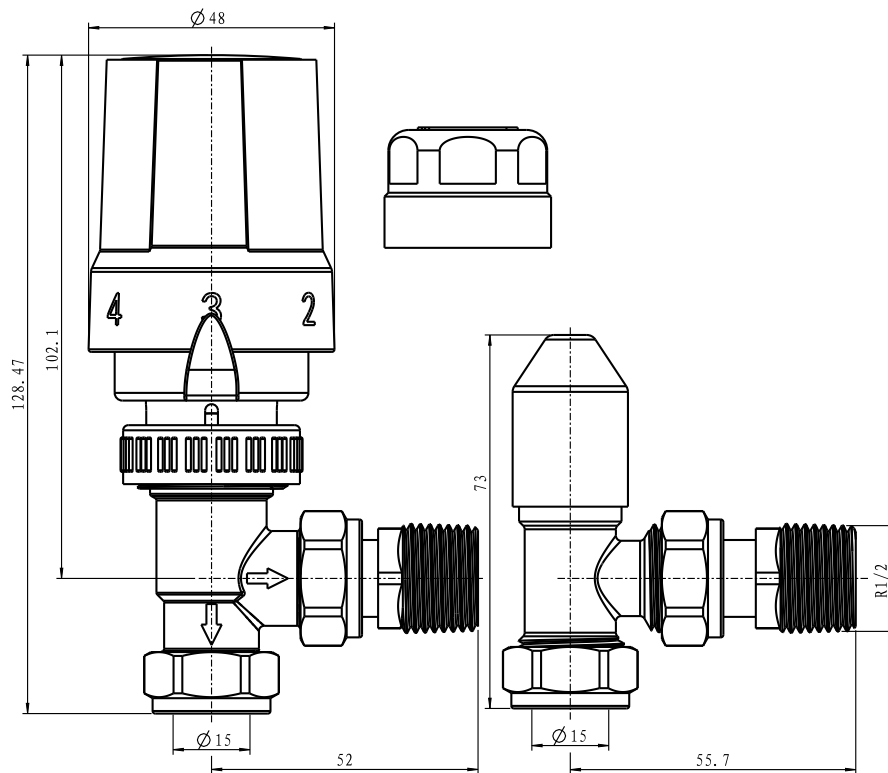

LT-15 Logic 15mm Angled TRV Twin Pack